

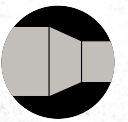

Fittings and
pipeline equipment

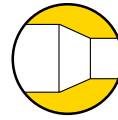





Fittings and pipeline equipment

4 **Quality control**

Insulating Joints

5–7 **Type SHD Monobloc**

8–9 **Type SHDFS**

10–11 **Type SHD Monobloc for water**

Insulating flange connections

12–13 **Type SIF PN 10 – PN 40**
Type SIFG PN 64, PN 100,
ANSI 150 – ANSI 900

14 **Type SIFW for water**

15 **Type HK-SIF-98**
Type HL-SIF-98
Type HL-SIF-T-98

Sleeves

16–17 **Socket sleeve Type SMU**
PN 16 – PN 100

18 **Type SU/SUA**
from DN 500
PN 16 – PN 100

Steel-PE adaptors

19 **Type PESS, DN 25 – DN 50**
Type PESV..., DN 25 – DN 800

Compensators

20–21 **Type SDS**

Pig traps

22 **Type SMO**

23 **Fittings**

In the assessment and selection of products in pipeline construction, operational safety, reliability as well as the long-term stability are always the top priorities.

The standard of quality that these products are required to meet becomes the criterion for a company's technical competency.

The products listed meet these strict requirements.



Quality

DIN ISO 9001

- DIN ISO 9001
- API
- HPO
- WO
- Component test 1066

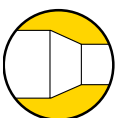

Insulating separation points (insulating elements/insulating flanges) are used for interrupting the metal conductivity of a pipe line or a cathodic corrosion protection system.

The innovative design and especially sturdy construction of these pre-assembled Type SHD insulating joints make them extremely reliable and capable of meeting the most exacting requirements.

Component-tested to VdTÜV 1066

- from PN 16 up to PN 320 and above
- from PN 25 up to PN 1600 and above

Design features

- ready to install, solidly joined, fully welded construction
- prefabricated and tested in the works
- with tear drop (guarantees max. safety)
- integrated PTB tested, patented annular breakdown voltage (Patent No. 389367 as well as tested at the German Federal Army Research Centre in Munich)
- standard
- with abrasion-resistant, non-conductive internal lining with a two-component approx. 100 μ thick coating to avoid shorting out in the case of possible dirt deposit in the internal part, or internal lining to customer specification

- external corrosion protection with heat-shrinkable sleeve to DIN 30672, or with polyurethane resin to DIN 30671, a solvent-free, airless hot-processed two-component coating material or corrosion protection to customer specification

Decades of experience based on constant trials and tests with prototypes guarantee a comprehensive, consistent quality.





Project: Trans-Austria Gas Piping DN 900 – DN 1200, PN 100

Range of applications

- Media: oil, gas, combustible liquids, brine, acid
- Below- and above-ground pipework
- Compressor stations
- Regulating stations, explosion protected



- Pipework and compressor regulating station from PN 16 up to PN 320 bar and above, ANSI 150, 300, 400, 600 >
- Pipelines up to DN 1600 mm and above
- Temperature range standard -10°C up to 50°C
- Special design -40°C up to 150°C

Manufacture and testing

- Component-tested to VdTÜV 1066, to DIN 2470 Part 1 and Part 2 or DVGW G 463, TRFL, ASME-Code and other international standards
- Customer specification
- Voltage proof by means of the finite elements calculation
- If there are no details available, manufacturing and testing are carried out to Schuck Standard
- Materials according to standard, specification or customer specification
- Final inspection according to DIN 2470 DGRL, TRFL, ASME or customer specification
- Certification to EN 10 204 / 3.1 (works

Annular spark gap

The design of our integrated annular spark gap ensures that if a voltage exceeding 5 kV occurs, it is generally negated by our annular spark connector.

The decisive point is that the integrated explosion spark gap is annular (as already indicated by the name)

As a result of the high voltage thus produced, it is possible to constantly guarantee the design distance required, for example, to maintain the 5 kV condition.

With a point-type design there is a danger that carbonisation or burn-off may occur.

With our patented annular spark gap this is not possible.

expert), 3.2 (TÜV) or other independent inspection authorities

Advantages

of an insulating joint as compared with a flanged connection

The advantages of a compact, prefabricated insulating joint as compared with a detachable, flanged connection are pointed out below:

- fully welded component
- flexurally rigid construction (in accordance to the available pipe-forces respectively actual bending torques)
- pressure test possible at the works
- not removable
- no loss of pre-stress power
- homogeneous, seamless external insulation
- external insulation tested electrically in the works
- integrated annular spark gap

An Explosion Proof Protection is demanded to be used in a compressor station and/or regulator station or other units which are protected installation in accordance with the guideline 94/9/EG (ATEX), we are authorized to issue an EC conformance for the manufacture of components to be used in an explosion hazardous area. These insulating pieces are equipped with an additional external spark protector.



- Installation instructions at www.schuck-armaturen.de

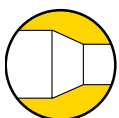

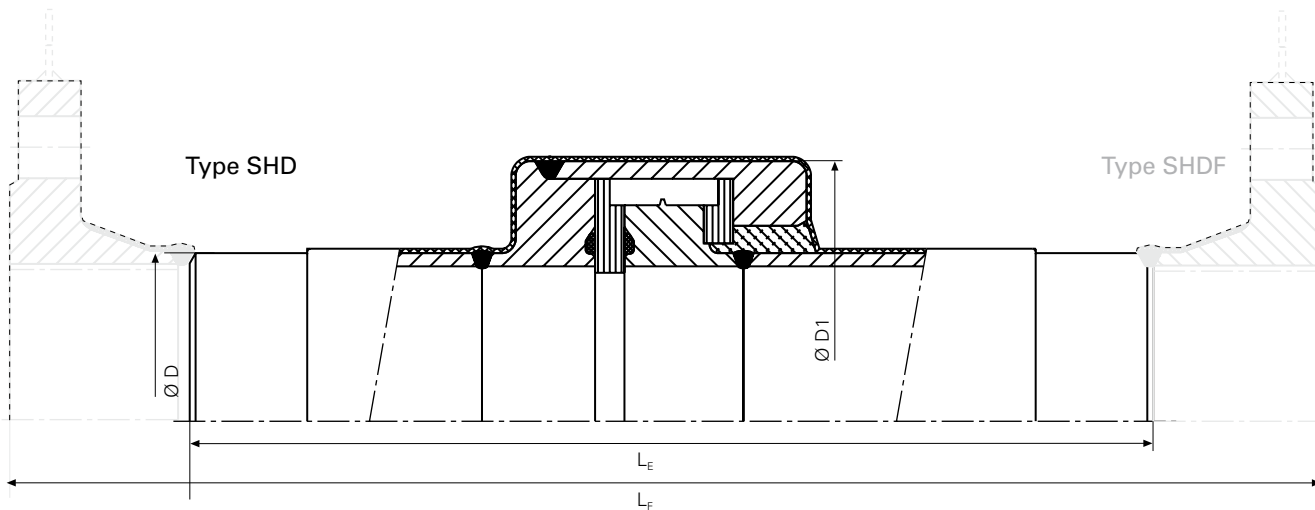

Inches	DN	SHD with welded connection both sides Joint shape 22, DIN 2559					SHDF with flanged connection both sides to DIN and ANSI					
		$\varnothing D$	PN 16–100 L_E	PN 16, 25, 40 $\varnothing D_1$	PN 70,100 $\varnothing D_1$	PN 10 L_F	PN 16 L_F	PN 25 L_F	PN 40 L_F	PN 64 L_F	ANSI 600 L_F	
1	25	33.7	500	78	78	200	200	220	220	260	260	
1 ¼	32	42.4	500	92	92	200	200	220	220	290	290	
1 ½	40	48.3	500	98	98	220	220	230	220	300	300	
2	50	60.3	700	110	110	220	220	230	230	280	320	
2 ½	65	76.1	700	130	130	220	220	230	240	290		
3	80	88.9	700	148	148	240	240	280	260	300	350	
4	100	114.3	700	172	172	240	240	280	280	305	360	
5	125	139.7	700	196	196	250	250	320	280	340	400	
6	150	168.3	700	222	224	250	250	320	320	360	430	
8	200	219.1	700	275	288	280	280	330	360	400	480	
10	250	273.0	700	328	350	290	300		380	430	520	
12	300	323.9	700	376	405	300	320	350	400	500	550	
14	350	355.6	700	412	442	300	330	380	420			
16	400	406.4	1000	468	508	300	330	420				
18	1450	457.0	1000	535	575							
20	500	508.0	1000	595	630							
24	600	610.0	1000	690	745							
28	700	711.0	1000	810	865							
32	800	813.0	1000	905	975							
36	900	914.0	1000	1025	1115							
40	1000	1016.0	1000	1130	1230							

This table shows the most important measurements at a glance.
Larger nominal diameters and other types of construction are possible without any difficulties.
Dimensions with permissible variations.

● Installation instructions at
www.schuck-armaturen.de

Technical data and description as SHD
Monobloc

Fire Safe on one side with flange connection and on the other side with welded connection, reinforced construction, as well as with Fire Safe Test. Based on BS6755 – Part 2 – 1987; Supplement No. 6712-1991. Specially suitable for fitting in plant construction (M+R plant).

- External protection:
with shrink hose to DIN 30672, if required with PUR coating to DIN 30671 or customer specification
- Standard without internal lining
- Internal coating:
two-component epoxy resin-based (Permacor), approx. 100 µ thick

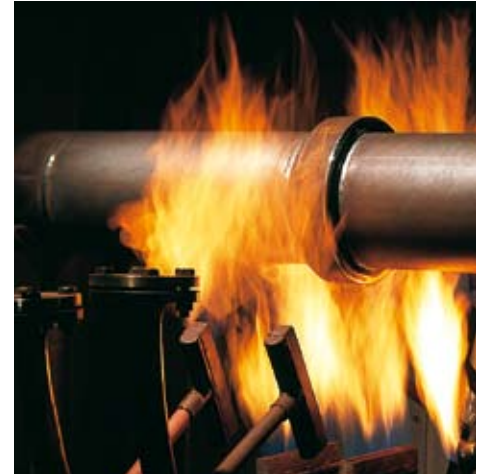

Patented, PTB-tested annular spark gap

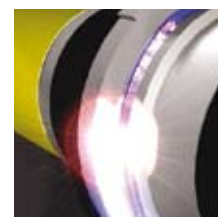
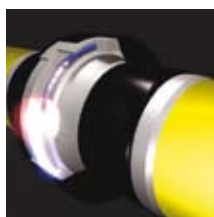

● Animation at
www.schuck-armaturen.de

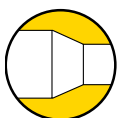

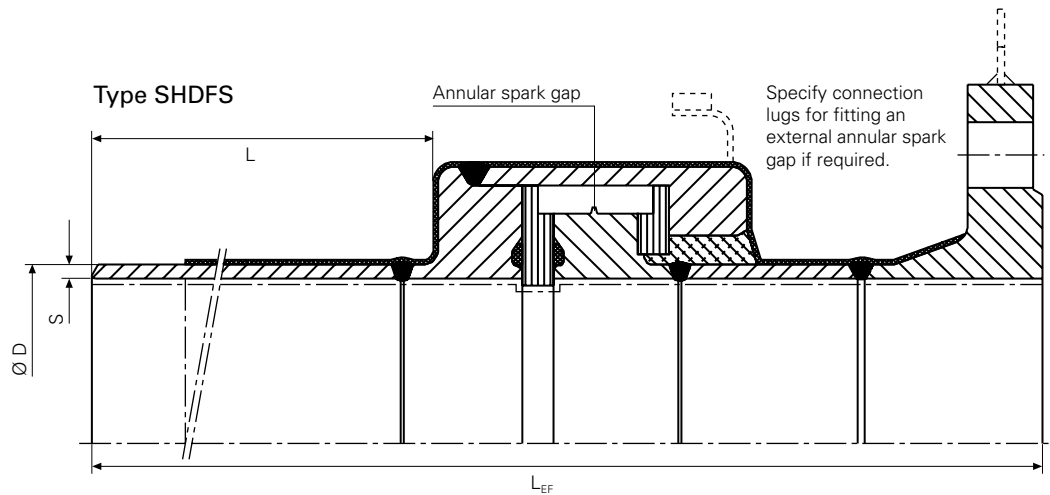

SHDFS overall lengths

Inches	DN	Ø D	L	L _{EF}	L	L _{EF}
			PN 16	PN 16 Flange DIN 2633	PN 70/100	PN 70/100 Flange ANSI 600
3	80	88.9	320	530	320	565
4	100	114.3/108	330	530	320	600
6	150	168.3/159	330	535	320	600
8	200	219.1	330	545	320	630
10	250	273	350	560	340	700
12	300	323.9	460	575	360	775
16	400	406.4	465	750	425	900
20	500	508.0	450	770	450	900

This table shows the most important measurements at a glance.
Larger nominal diameters and other types of construction are possible without any difficulties.
Dimensions with permissible variations.

- If required with welded-on connection lugs for providing an additional external explosion spark gap.



Design features

- as Type SHD symmetrical or asymmetrical construction (as required)
- internal lining with an epoxy resin-based highly abrasion-resistant two-component coating with a layer thickness from 300 up to 400 µm, with KTW recommendation (potable water-resistant), or
- internal lining with cement mortar, potable water-resistant, on pre-treated, primed metal surface, or
- internal lining with electrostatic special powder spraying process (used for very corrosive media) or internal structure with skimming (3–5 mm) for water mixed with abrasive substances, or
- internal lining to customer specification
- corrosion protection externally with heat-shrinkable sleeve to DIN 30672, or
- with PUR Coating (Protegol PUR coating; a solvent-free, airless hot-processed two-component coating material with short reaction time), or
- external corrosion protection to customer specification

Decades of experience in the water sector have made us the market leader.

Scope of application

- Media: potable water, water, waste water, salt water
- pipework below or above ground
- pipework PN 4 up to PN 64 and above
- flange connections to DIN, ANSI and customer specification
- pipework up to DN 1600 and above
- temperature range up to 50°C (standard)
- please name higher temperature ranges on request or order

Manufacture and testing

- to Schuck standard or customer specification
- component test to VdTÜV Code of Practice 1066 (acc. to requirements for gas)
- calculation to AD Codes of Practice
- steel materials to DIN or EN
- insulating and sealing materials for specific temperatures and media
- visual check
- dimensional verification
- electrical test 2000 V (50 Hz), d.c. 500 V/0.1 megaohm in dry condition
- pressure test as required 1.5 x PN
- inspection according to EN 10 204 / 2.2, 3.1, or
- to customer specification
- additional forces, flexural torques must, if necessary, be specified by the customer

Dimensions

- The effectiveness of the internal coating depends on the diameter of the isolating point, the specific electrical resistance of the medium and on the voltage applied at the isolating point
- If no values are available, an electrically insulating internal coating of at least 200 mm or 3x DN is recommended. This is because some of the components are asymmetrical, to keep dimensions within limits
- Dimensions to customer specification

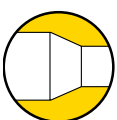

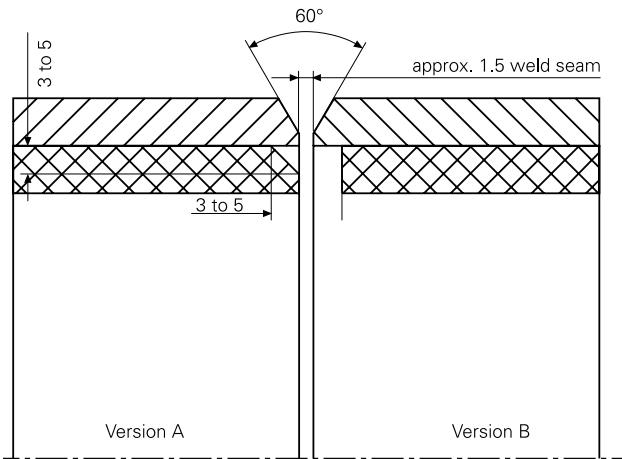

Preparation for butt-welded jointing on pipes with cement mortar lining up to the pipe end

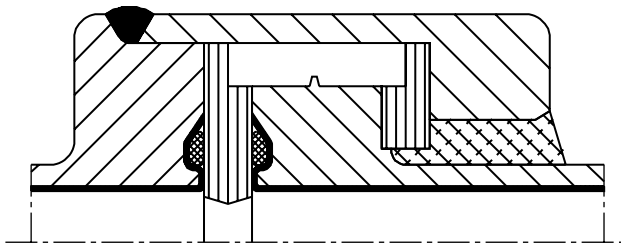

Type SHD

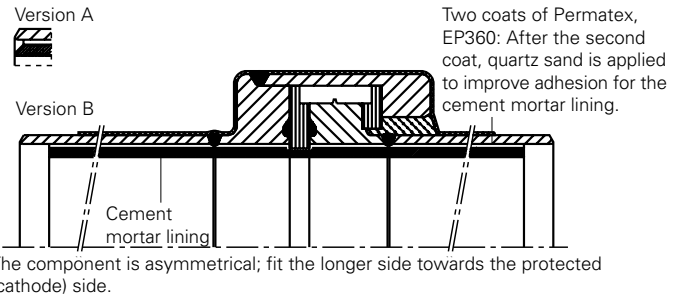

Type SHDF

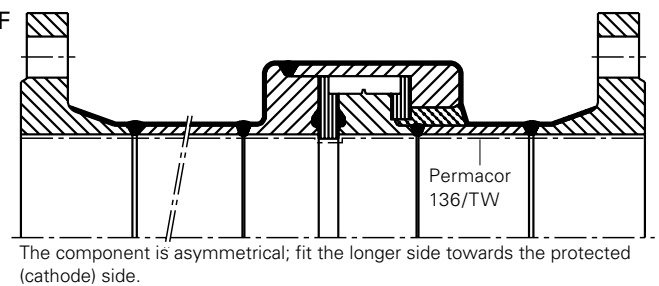

Type SHDFS

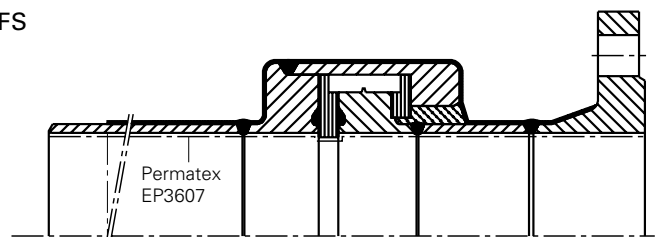

Overall lengths for insulating joints for water

If the customer does not specify any overall lengths or details about the conductivity or the specific resistance of the medium, which are necessary for determining the overall lengths, the following overall lengths apply.

Type SHD			Type SHDF/ SHDFS		
DN	Overall length mm	insulating clearance mm	DN	Overall length mm	insulating clearance mm
100	1100	820	100	1000	820
150	1300	1010	150	1200	1010
200	1500	1160	200	1300	1160
250	1600	1300	250	1500	1300
300	1700	1420	300	1600	1420
400	2000	1640	400	1800	1640
500	2200	1840	500	2000	1840
600	2400	2010	600	2200	2010
700	2750	2170	700	2400	2170
800	2900	2320	800	2550	2320
900	3050	2460	900	2700	2460
1000	3250	2600	1000	2900	2600

Construction length or insulating clearance referring to a water-conductivity of 600 micros/cm

Version I, II, III, IV



Design features

- electrically insulating flanged connection
- detachable
- with weld end
- if required with pipe connecting socket welded on both sides, length to customer specification
- without internal lining
- without external corrosion protection
- supply and installation of an explosion spark gap element on request
- due to the seal design, further retightening is no longer required after initial pressurisation and single retightening of the screws

Application range

- gas, oil, combustible liquids
- temperature range –10°C up to 50°C
- up to DN 1000 and above
- PN 6 up to PN 100 or ANSI 150 up to ANSI 600

Manufacture and testing

- to DIN 30690, DIN 2470 Part 1 and Part 2 or DVGW G 463, TRFL
- to customer specification
- to Schuck standard
- without pressure test, or
- pressure test to customer requirements
- inspection test to EN 10 204 / 3.1, 3.2, or
- inspection test by the customer

Overall lengths Type SIF PN 10 – PN 40

DN	Pipe connection ISO mm	PN 10			PN 16			PN 25			PN 40		
		Overall length mm	Weight kg	Version	Overall length mm	Weight kg	Version	Overall length mm	Weight kg	Version	Overall length mm	Weight kg	Version
25	33.7	89	3.0	I/III	89	3.0	I/III	93	3.3	I/III	93	3.3	I/III
32	42.4	93	4.5	I/III	93	4.5	I/III	97	5.0	I/III	97	5.0	I/III
40	48.3	97	5.0	I/III	97	5.0	I/III	103	6.0	I/III	103	6.0	I/III
50	60.3	103	6.4	I/III	103	6.4	I/III	109	7.0	I/III	109	7.0	I/III
65	76.1	103	7.5	I/III	103	7.5	I/III	117	9.5	I/III	117	9.5	I/III
80	88.9	113	8.6	I/III	113	8.6	I/III	129	12.0	I/III	129	12.0	I/III
100	114.3	117	12.0	I/III	117	12.0	I/III	143	17.5	I/III	143	17.5	I/III
125	139.7	123	15.5	I/III	123	15.5	I/III	149	25.0	I/III	149	25.0	I/III
150	168.3	123	18.5	I/III	123	18.5	I/III	163	31.0	I/III	163	31.0	I/III
200	219.1	137	27.0	I/III	137	29.0	I/III	173	44.0	I/III	189	57.0	I/III
250	273	149	36.0	I/III	153	41.5	I/III	189	63.5	I/III	223	90.0	II
300	323.9	149	42.0	I/III	169	55.0	I/III	197	82.0	I/III	243	127.0	II
350	355.6	149	52.0	I/III	177	72.0	I/III	213	117.0	I/III	263	173.0	II
400	406.4	157	67.0	I/III	184	93.0	I/III	233	153.0	I/III	283	242.0	II
500	508	163	87.5	I/III	193	150.0	I/III	263	218.0	I/III	293	305	II
600	609.6	173	108.0	I/III	204	189.0	I/III	260	260.0	II			
700	711.2	173	149.0	I/III	210	199.0	II	260	340.0	II			
800	812.8	193	202.0	I/III	220	264.0	II	280	485.0	II			
900	914.4	203	238.0	I/III	230	314.0	II	300	608.0	II			
1000	1016	203	283.0	I/III	248	411.0	II	318	810.0	II			

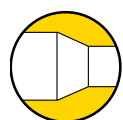

Version SIF-G

Manufacture and testing

- to DIN 30 690 or DIN 2470 Part 2 or DVGW G 463, TRFL
- without pressure test
- in-plant 'Fire Safe-Test' based on BS6755 – Part 2 – 1987, Supplement No. 6712-1991
- flanges in accordance with ANSI (ASA) B 16.5 RF (flat sealing surface)
- inspection test to EN 10 204 / 3.1, 3.2

The individual components of our standard insulating flange connections can also be supplied as a retrofitting set for existing flanges.

Versions II and III also suitable for use in the water sector (for details of application range as well as manufacture and testing, see SIFW).



Overall lengths Type SIFG PN 64, PN 100, ANSI 150 to ANSI 900

DN	Pipe connection ISO mm	PN 64 Overall length mm	PN 100 Overall length mm	ANSI 150 Overall length mm	ANSI 300 Overall length mm	ANSI 600 Overall length mm	ANSI 900 Overall length mm
25	33.7	120	120	115	128	141	164
40	48.3	128	128	128	141	156	182
50	60.3	128	140	131	144	163	220
65	76.1	140	156	144	156	176	226
80	88.9	148	160	144	163	182	220
100	114.3	160	184	156	175	220	245
125	139.7	180	214	182	201	245	271
150	138.3	194	234	182	201	252	296
200	219.1	224	264	207	226	283	341
250	273	254	318	207	239	322	385
300	323.9	284	344	233	264	328	417
350	355.6	304	382	258	290	347	443
400	406.4	324		258	296	372	449

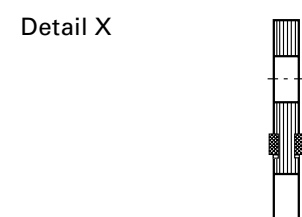
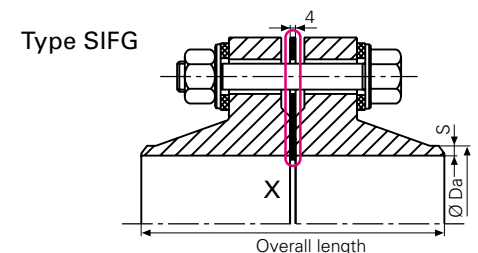
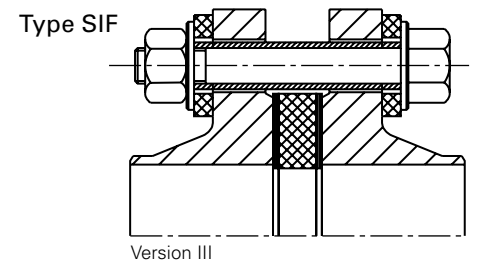
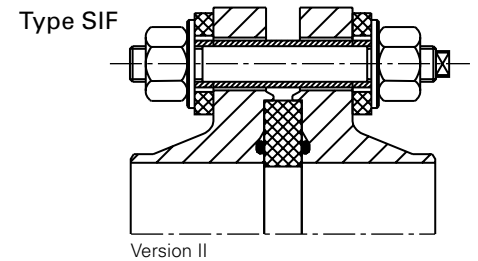
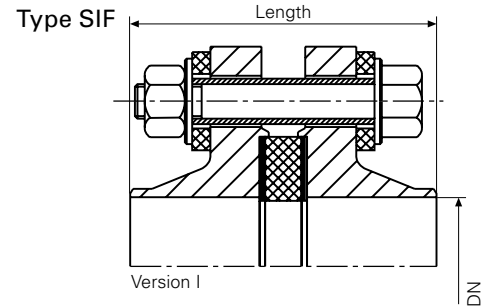

Adhesion

Here are the most important measurements at a glance. Larger nominal diameters and other types of construction are possible. Dimensions with permissible size tolerances.

Design features

- electrically insulating flanged connection
- detachable
- with weld end
- if required, with welded-on pipe connecting sleeve, length to customer specification
- without internal lining
- without external corrosion protection
- due the sealing arrangement, further retightening is no longer required after initial tightening of the bolts

Advantages

- maintenance-free, since retightening of the bolts is not required
- protected against blow-out by compartmentalised sealing rings in grooves
- permanently flexible through O-ring-type silicone seals
- **suitable for high stresses through secondary frictional connection of the seals**
- reliable as a result of minimal water absorption, durable insulating properties
- easy fitting through compact insulating gasket (only one gasket), simplifying the work of changing this insulating sealing ring
- type of construction, recessing of the flanges is not necessary

Applications

- water, potable water
- operating temperature up to 50°C
- pressure stage PN 6 up to PN 40 and above
- for pipework up to 1200 mm and above

Manufacture and testing

- to customer specification
- to Schuck standard based on DIN 3389 (PN 4 < PN 16) DIN 1988 for > PN 16
- electrical test 2000 V (50 Hz), d.c. 500 V/0.1 megaohm in dry condition
- without pressure test
- insulating material and sealing material to suit the mechanical, electrical and thermal requirements of the water
- flanges to DIN or ANSI with flat sealing face RF

DN	Pipe connection mm	PN 10	PN 16	PN 25
		Total lgth	Total lgth	Total lgth
25	33.7	74	74	84
40	48.3	88	88	94
50	60.3	94	94	100
65	76.1	94	94	108
80	88.9	104	104	120
100	114.3	108	108	134
125	139.7	114	114	140
200	219.1	128	128	164
250	273	140	144	180
300	323.9	140	160	188
350	355.6	140	168	204
400	406.4	148	174	224
500	508	154	184	254
600	609.6	164	194	254
700	711.2	164	204	254
800	812.8	184	214	274

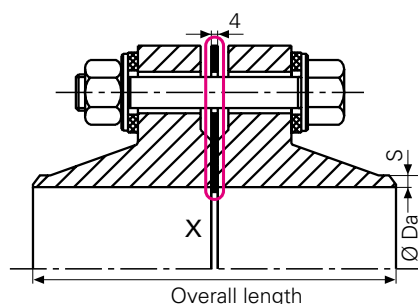

Detail X

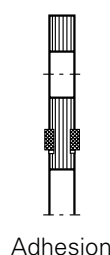

Here are the most important dimension details.
Larger nominal diameters and other types of construction are possible.
Overall measurements with permissible measurement tolerances.

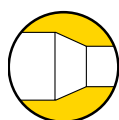

Type HK-SIF-98

Type HL-SIF-98

Type HL-SIF-T-98

for district heating

Design features

- ready to install, electrically insulating and direct-contact flanged connection
- both sides with welded-on pipe branch
- prepared and assembled at the works so that the components can be installed complete in the piping without dismantling
- specially developed IsoSeal D 200 medium insulating ring with compartmentalised graphite inlay, intended for flanges with non-raised sealing surface
- HK-SIF-98 without internal lining
- HL-SIF-T-98 internal Teflon lining
- HL-SIF-98 internal epoxide resin lining; the internal lining extends the electrical isolating distance

Applications

- insulating flange connections for district heating, pressurised hot water/steam
- operating temperature HK-SIF-98 to 200°C
- HL-SIF-T-98 to 200°C
- HL-SIF-98 to 180°C
- **higher operating temperature on request**

Manufacture and testing

- to Schuck standard
- electrical test in the dry condition
- breakdown test AC 2000 V (50 Hz)
- resistance test DC 500 / V 0.1 megaohm

Dimensions

- the effectiveness of the internal coating depends on the diameter of the insulating flange connection, specific electrical resistance of the medium and the voltage applied at the insulating flange connection
- should no values have been specified, an electrically insulating internal coating of at least 200 mm is recommended. This is why the components are sometimes asymmetrical, to restrict dimensions
- dimensions as specified by the customer



Type HK-SIF-98

t = 200°C

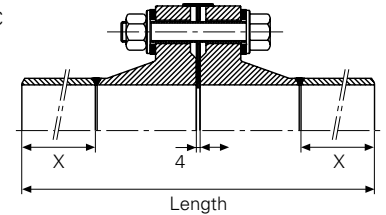

Type HL-SIF-T-98

t = 180°C

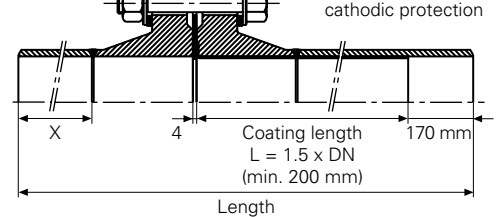

Type HL-SIF-98

t = 200°C

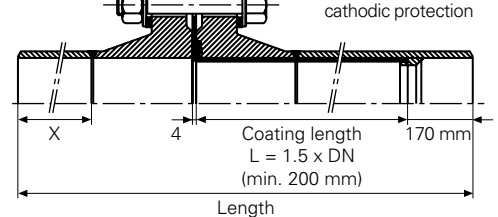

If required, coating length L possible with 3 x DN and over

- X = up to DN 300: 100 mm
- up to DN 500: 200 mm
- over DN 500: 300 mm

Face-to-face length in mm with weld seam preparation at both sides to DIN 2559 joint form 22

DN	HL-SIF-T-98 and HL-SIF-98				HK-SIF-98			
	PN 10 OL	PN 16 OL	PN 25 OL	PN 40 OL	PN 10 OL	PN 16 OL	PN 25 OL	PN 40 OL
25		515		520		285		290
32		520		520		290		295
40		520		525		295		300
50		525		525		300		305
65		525		530		300		315
80		530		535		310		326
100		530		545		315		340
125		530		545		320		345
150		560		580		320		360
200	640	640	660	665	335	335	370	385
250	720	725	740	760	345	350	385	420
300	795	805	820	845	345	365	395	440
400	1050	1062	1090	1115	555	580	630	680
500	1200	1220	1255	1270	560	590	660	690

Here are the most important measurements at a glance.
Larger nominal diameters and other types of construction are possible.
Dimensions with permissible variations.
OL = overall length

Self-sealing connection element for gas pipeline under pressure, Patent-No. 24 42 227

Design features

- screw-less, self-sealing connection elements
- from PN 40 and DN 300 in the form of machined collar rings in accordance with AD Code of Practice W 13
- the sealing chamber has been designed so that sealing takes place automatically even at low internal pressures in the pipe system

Range of applications

- as a connecting element for connecting pipe systems under gas pressure
- as a safe alternative to cost-intensive flanging and interlinking
- connection of different pipe sizes
- operating medium: gas
- pipe system PN 16 to PN 100
- pipe system DN 25 to DN 400
- temperature range: -10°C to 50°C
- installation above ground and underground

Manufacture and testing

- to DIN 2470 Part 1 and DVGW G 463
- to customer specification
- inspection testing to EN 10204/3.1. or 3.2

Advantages

- the installation time is reduced by more than half the previous requirement
- bypasses are virtually not required
- road blocks are only needed for a brief period. With careful preparation a pipe system can be brought back into service at reduced pressure after 15 to 20 minutes. In many cases this dispenses with a costly bypass operation
- there is no longer any danger of accidents leading to severe burns
- flanging - which is dubious from the metallurgical point of view, can be dispensed with



The SMU is pushed with a slightly rotating motion onto the lubricated pipeline.

Further information at:

www.schuck-armaturen.de

Version PN 70/PN 100



	DN	da	Overall length
	50	60.3	300
	80	88.9	300
	100	114.3	300
	150	168.3	300
	200	219.1	400
	250	273	400
	300	323.9	400
	400	406.4	400

Here are the most important measurements. Larger nominal diameters and other types of construction are possible.
Dimensions with permissible variations.

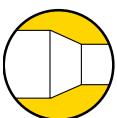

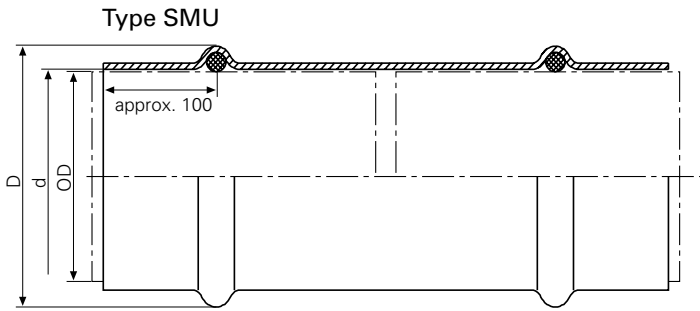

On both sides to slip over for same pipe connecting dimensions

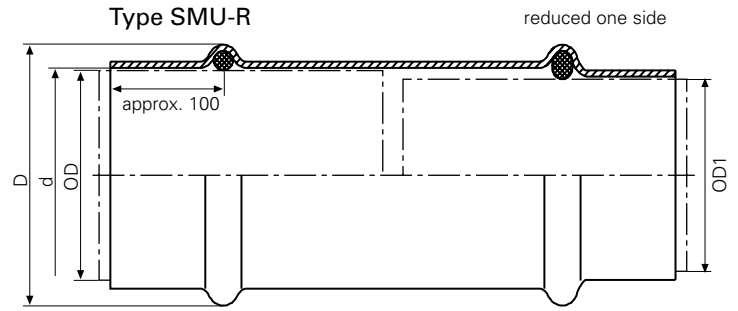

On both sides to slip over, one side reduced (different pipe dimensions)

Type SMU-1

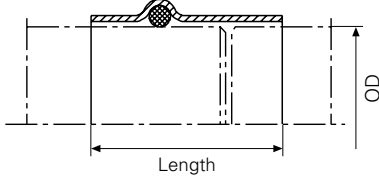

A half sleeve, on one side to slip over, other side to weld on with fillet weld

Type SMU-S

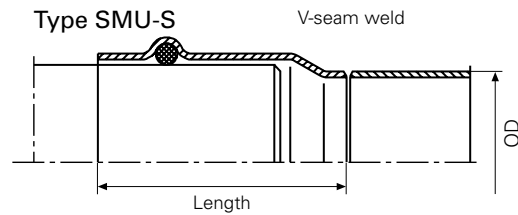

A half sleeve, on one side to slip over, other side to weld on with single V groove weld

Type SMU-K

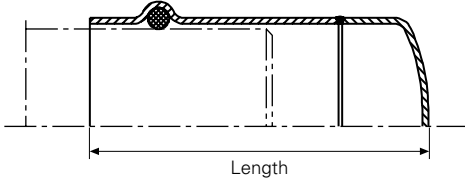

A half sleeve, on one side to slip over, other side with welded closing cap

Type SMU-F

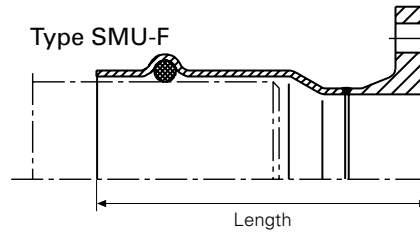

A half sleeve, on one side to slip over, other side with flange

● = seal ring

Steel pipe DN	da	D	d	Type SMU Stand. OL	Type SMU-S Overall lgth	Type SMU-F Overall lgth	Type SMU-1 Overall lgth	Type SMU-K Overall lgth	Type SMU-R da	OV. I., as for Type SMU da1
25	33.7	60.5	36	420	210	245	210	160		
32	42.4	78	44.6	420	210	245	210	160		
40	48.3	78	50	420	210	250	210	160	48.3	44.5
50	60.3	90	63	420	210	250	210	160	60.3	57
65	76.1	103.5	78.9	420	210	250	210	160	76.1	70
80	88.9	120	91.6	500	250	300	250	260	88.9	80
100	108	138.5	111	500	250	300	250	260	88.9	82.5
100	114.3	145	117	500	250	300	250	260	114.3	108
125	133	163	137	500	250	305	250	260	139.7	133
125	139.7	169	143.4	500	250	305	250	260	168.3	159
150	159	198	162.5	500	250	305	250	260	219.1	209
150	168.3	207	172	500	250	305	250	260	219.1	211
200	219.1	258	222.5	500	250	310	250	260	219.1	214
250	273	316	278.5	500	250	320	250	330	219.1	216
300	318	369	323	500	250	320	250	350	273	263
300	323.9	369	329	500	250	320	250	350	273	267
350	355.6		360	500		290			323.9	318
400	406.4	453	411	500	250	330	250	350	406.4	419

Here are the most important measurements.
Larger nominal diameters and other types of construction are possible.
Dimensions with permissible variations (schedule valid up to PN 40).
Ex DN 250 hot formed up to PN 25.

● Fitting instructions at
www.schuck-armaturen.de

**Design differences compared with
Type SMU**

- sealing connection element in the form of turned collar rings in accordance with AD Code of Practice W 13 with intermediate welded-in pipe sections
- with inserted special profiled sealing ring in the sealing chamber of the collar ring
- sealing is achieved by tightening the allen screws in the external face of the collar ring
- tightening the screws squeezes the rubber profile via the metal adjusting ring, resulting in a reliable and controlled sealing effect against the pipe media
- after sealing, the allen screws are cut off flush with the collar ring
- the profiled seal is not destroyed if welding is carried out expertly
- finally, the sleeve must be welded to the metal pipe
- to achieve a better weld, as well as obtaining a more effective test of the sleeve / medium pipe weld, we recommend the fitting of weld-on collars on both sides – if necessary, flanging the weld-on collars will reduce the gap between the weld-on collars to a minimum.
- on one side for pushing over, on the other side with V-flange and weld-on collar Type SUFA
- on one side for pushing over, on the other side with dished boiler end or end cover Type SUK
- on one side for pushing over, on the other side with dished boiler end or end cover and Type SUKA weld-on collar
- corrosion protection inside and unprotected black outside
- without pressure test at the works as standard
- with pressure test at the works on request
- acceptance testing to EN 10 204, 3.1 or 3.2

Type SU

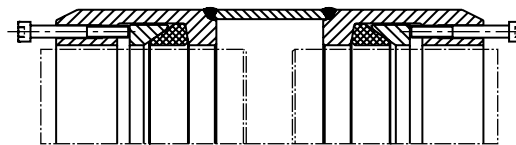

Type SUA

The weld-on collar is supplied loose

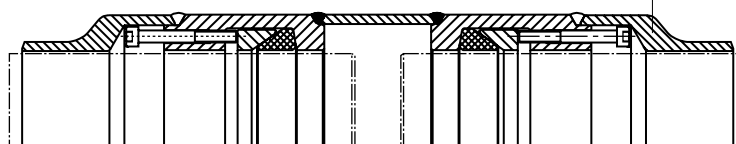

DN	Overall length
500/508	500
600/610	500
700/711	700
800/813	700
900/914	800
1000/1016	900

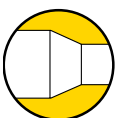

Design features

Steel-PE adaptors for the connection of steel piping systems with polyethylene piping in the gas sector. High tensile, torsional and pressure strength. Suitable for all current PE-HD welding processes as well as sufficient additional length for second and third welding of the PE-HD connection element are characteristics of this type series which facilitate their use. Possible with weld end, flange connection or sleeve.

Application range

Suitable for connecting steel with PE-HD pipes in accordance with the recommendations of the DVGW (German Gas- and Water Engineers' Association) Code of Practice G 477. Available nom. diameters with pressure stage: DN 25 – DN 800, PN 10 Materials: PE 100, SDR 11, PN 10 (standard)

Only extruded PE pipe from established and approved pipe manufacturers is used. PE-HD pipes can also be used in all cases, to meet customer specifications.

Manufacture and tests

Requirements and tests to DIN EN 1555-2, GW 335-A2, DVGW-VP 600. All nom. diameters DVGW-approved. DN 25 – 200 DVGW (German Gas- and Water Engineers' Association) nos. from DN 250 DVGW, test confirmation or acceptance test certificate 3.1 in accordance with EN 10204.

Important features

- multiple welding made possible by extended polyethylene end
- chambered PE-HD pipe, preventing leaks resulting from the effects of heat or cold
- additional O-ring seal

**PESS (DN 25 – DN 50)
PESVS (DN 80 – DN 200)**

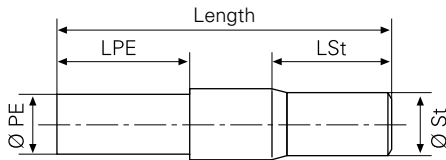

One side with PE end, the other side with weld end (steel)

PESVF

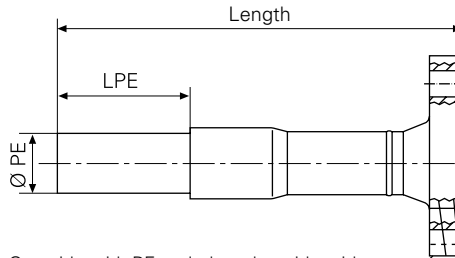

One side with PE end, the other side with flange connection

PESVU

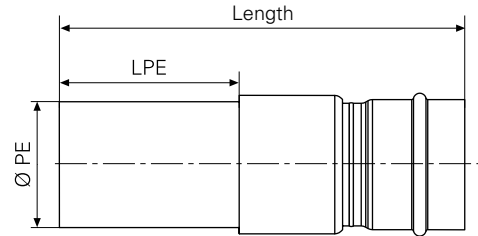

One side with PE end, the other side pushed over a steel pipe

DN	Ø PE	LPE	Ø St	L St	PESS Overall length	PESVS Overall length	PESVF Overall length	PESVU Overall length
25	32	120	33.7	240	500		370	450
32	40	120	42.4	240	500		360	460
40	50	130	48.3	240	500		370	460
50	63	130	60.3	240	500		380	490
80	90	250	88.9	250		575	410	620
100	110	250	114.3	250		590	410	610
	125	250	114.3	250		600	430	630
150	160	250	168.3	250		630	460	650
	180	250	168.3	250		650	480	700
200	225	330	219.1	250		760	600	790

Attention: At the dimension DPE 200 and from DPE 250 the PE pipe has to be delivered to the workshop from Customers side (free our works). Special size/water application on request.

Maintenance-free, self-sealing design



Design features

- maintenance-free, self-sealing expansion joint
- both sides with weld chamfer to DIN 2559, flange connection or PE connection
- expansion joint guides and expansion joint seals consist of independent systems
- expansion joint sealing is achieved by two separate, double-sealing systems
- both sealing systems can be tested individually
- a coarse wiper arrangement in brass with follow-on fine wiper prevents the entry of extremely small particles (e.g. dust, sand etc.)
- freely running guides allow length to be easily changed on site
- permanent lubrication of all movable systems
- protection of the parts exposed to corrosion by hard chromium plating, hot galvanising and polyurethane resin coating
- corrosion protection: inside untreated, outside PUR DIN 30 671 polyurethane resin coating
- weld ends 50 mm plain without covering and temporarily protected against corrosion

Range of applications

- compensation for length changes in pipe runs, e.g. ground settlement areas or thermal longitudinal expansions (e.g. long-distance district heating pipe runs)
- gas and oil pipelines
- water piping, cold and hot
- temperature range from -10°C to 50°C (Enquiries about long distance district heating welcomed)

Manufacture and testing

- to DIN 2470 Part 1 and 2, TRFL, ASME-Code-Section VIII Div. 1 and customer specifications
- acceptance testing to EN 10 204, 3.1 or 3.2

Accessories

- arresting arrangement, e.g. for pressure tests
- electro-mechanical expansion measuring appliance Type Pecont to measure the expansion element position or expansion element movement display

DN	Ø D	s	Overall length
80	88.9	4.0	2200
100	114.3	4.0	2200
150	168.3	5.0	2200
200	219.1	6.3	2300
250	273.0	6.3	2400
300	323.9	7.1	2500
400	406.4	8.8	2600
500	508.0	11.0	2700
600	610.0	10.0	2800

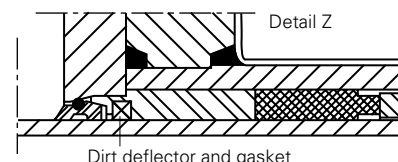

Here are the most important dimensions.
Larger nom. diameters and other types of construction are possible.
Dimensions with permissible size tolerances.

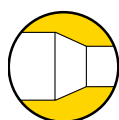

Advantages

- two separately operating rod sealing sets
- no retightening of the seals and gaskets required
- large sections allow transmission of extremely high bending moments and trouble-free movement under flexure
- defined separation of sealing results in greater security
- combined wiper system with metallic and non-metallic wipers provides a high degree of protection against penetration of dirt and sand
- grease envelope ensures long-term lubrication of the sliding surface and largely prevents the adhesion of the gasket
- test access port for the separate leak inspection of the primary or secondary seal
- possible damage to the telescopic pipe does not as a rule cause leaks because of the distance between the seals, one sealing set usually remains in contact with an undamaged telescopic pipe sliding surface
- the expansion unit can be relatively easily adjusted
- suitable for all pressures
- the expansion units can be coated with PUR beforehand at the works

Recommendation

We recommend the use of our patented PECONT electronic expansion measuring unit to measure movements in the installed expansion joint. If this is required, the support mountings should be attached beforehand at the works to avoid unnecessary on-site welding and insulation work.

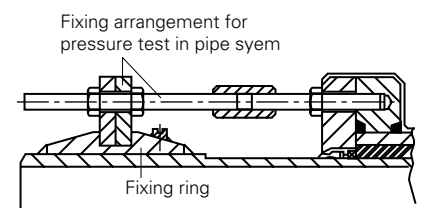
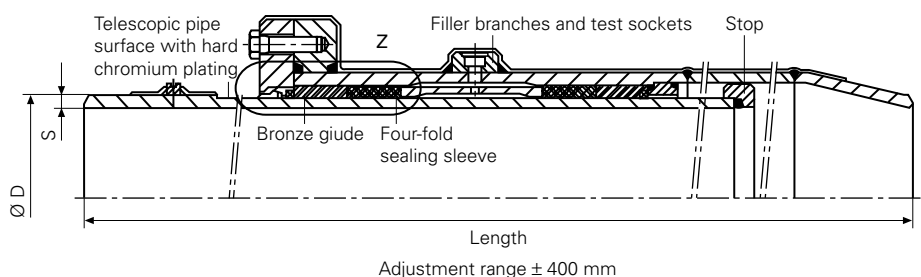

● Installation instruction at www.schuck-armaturen.de

Design features

- according to customer drawing supplied, otherwise standard as shown in sketch
- welded steel construction with manually operated quick-action bayonet closure
- optionally flanged- or welded joint
- with pig trap signalling unit
- surfaces sandblasted
- corrosion protection as required

Application range

- media: oil, gas, combustible liquids
- for use under and above ground
- PN 16, 25, 40, 70, 100, 150
- ANSI 150, 300, 400, 600, 900
- up to DN 1600
- temperature range -10°C up to 50°C
- special design -40°C up to 150°C



Manufacture and testing

- to DIN 2470 Part 1 or DVGW G 463, TRFL, ASME Code and other international standards or specifications
- customer specification
- if no requirements are specified, manufacture and testing are carried out to Schuck standard
- material according to standard, specification or customer order
- acceptance testing to DIN 2470, TRFL, DRGL or customer specification
- certification to EN 10 204, 3.1 and 3.2

The closure

Components

- coupling ring with lip seal, nitrile rubber quality
- cover with catch recesses on the bayonet teeth
- safety arrangement in the form of
- bayonet lock and pressure warning arrangement for the opening process
- arrangement for turning the cover, with catch device
- replacement lip seal for the bayonet closure

Complete pig trap station

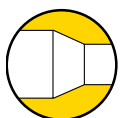
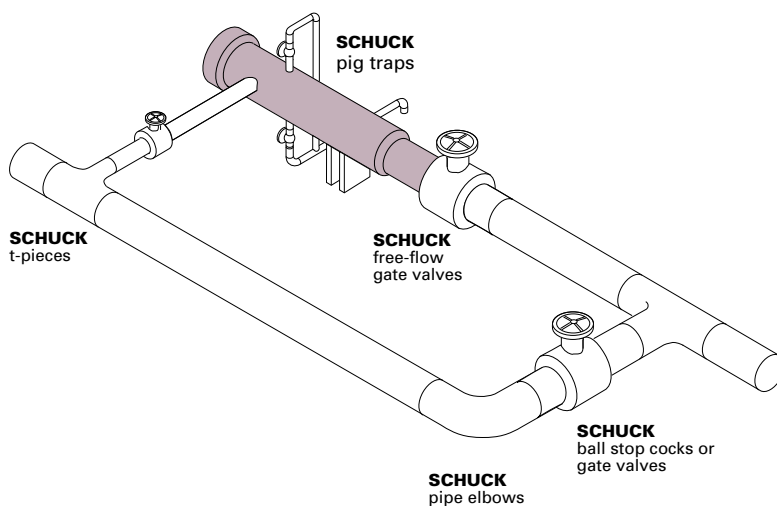

Design

- T-pieces with hot profiled or welded-on branches in all nominal diameters and pressure stages
- as individual fittings or a distribution system with several collar or branches (headers etc.)
- if required with scraper guide plates
- for use in water piping, an internal lining in concrete or plastic can be provided
- rust removal by sandblasting is carried out in our own large sandblasting plant
- processing and test facilities enable many corrosion protection systems to be applied
- heat treatment in the high-performance annealing furnace with temperature control and diagram recorder

Application range

- oil, gas, sour gas and water in pipeline- and plant construction
- temperature range standard -10°C to $+50^{\circ}\text{C}$; special construction -40°C to $+150^{\circ}\text{C}$; installation under- and above ground; nominal diameters up to DN 1600; PN 6 to 320
- other application ranges please enquire

- **Details of dimensions and design available on request:**
Tel. +49 7329 950-157



Manufacture and testing

- to DIN 2470 Part 1 or DVGW G 463, TRFL, ASME- Code and other international standards or specifications
- customer specification
- if no details are specified, manufacture and testing are carried to Schuck standard
- material according to standard, specification or customer details
- acceptance testing to DIN 2470, TRFL, DGRL, ASME or customer specification
- certification to EN 10 204, 3.1 and 3.2



Condensation test point

divided T-piece

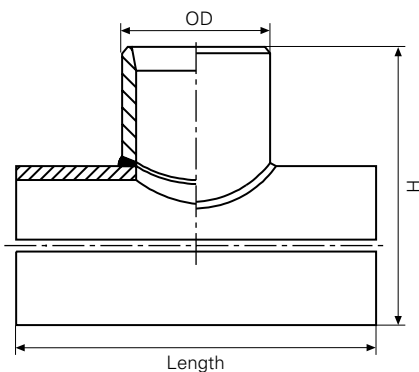

T-piece extruded

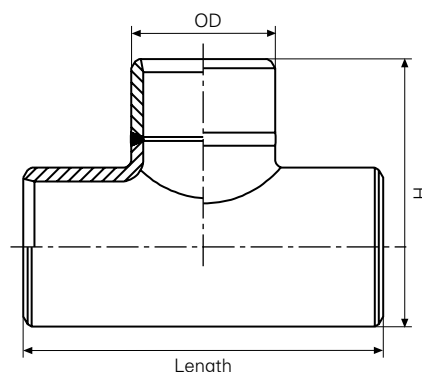

reducing adapter

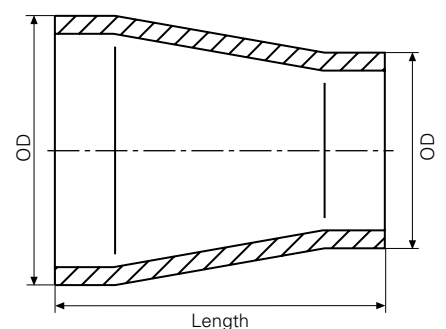

Schuck connects.



Schuck supplies all the various systems used to deliver gas, oil, water or district heating from the source to the user. As a systems supplier Schuck sets the standards worldwide. All products and services are carefully co-ordinated with one another. "Supply requires complete systems."

International energy suppliers appreciate the advantages that come with compatibility, functionality, reliable guarantees and efficiency.

Franz Schuck GmbH

Daimlerstraße 4 – 7
89555 Steinheim
Germany
Phone +49 7329 950-0
Fax +49 7329 950-161
info@schuck-armaturen.de
www.schuck-armaturen.de

Request individual brochures or download them from the Internet as PDF files.